

# JA-110B Bus acoustic glassbreak detector

The JA-110B is component of the JABLOTRON system. It is used to detect the breaking of glass window panes and glass surfaces in buildings. It reacts to the change of air pressure accompanied by the characteristic sound of breaking glass. The detector has a pulse reaction (only reports its triggering). The detector should be installed by a trained technician with a valid certificate issued by an authorized distributor.

## Installation

The detector should be installed in the interior. There should be no sources of noise, vibration emitting devices or moving objects which can create a shock wave in its detection field. It is also not recommended to install the detector in places with over-intense air circulation (close to ventilators, heat sources, air conditioning outlets, non-airtight doors, etc.). There should be no sound-absorbing obstacles (e.g. heavy curtains) in front of the detector.

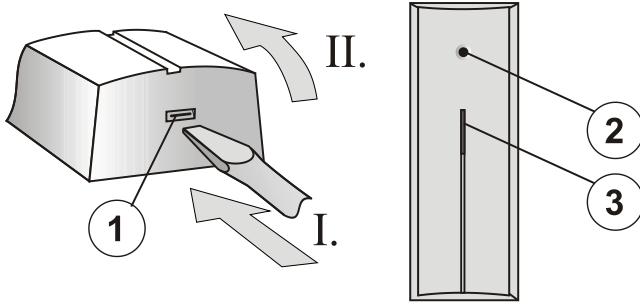

Figure: 1 – cover tab; 2 – sensor; 3 – activation and fault signalling

1. **Open the detector cover** by pushing the tab (1).
2. **Take out the PCB** – it is held with a tab (5)
3. Insert the bus cable and attach the plastic base to the wall using screws.



**When connecting the detector to the system bus, always switch the power off.**

4. **Insert the PCB back** and connect bus cables to the terminals (6).
5. Proceed according to the control panel installation manual.  
Basic procedure:
  - a. When the detector is switched on, the yellow LED (9) starts flashing repeatedly to indicate that it has not been enrolled into the system.
  - b. Go to the **F-Link** program, select the required position in the **Devices** window and launch the enrollment mode by clicking on the Enroll option.
  - c. Press the tamper contact in the detector (11) – the detector is thus enrolled and the yellow LED indicator goes off.
6. Close the detector cover and make sure that the rubber part of the sensor does not cover the opening in the cover.

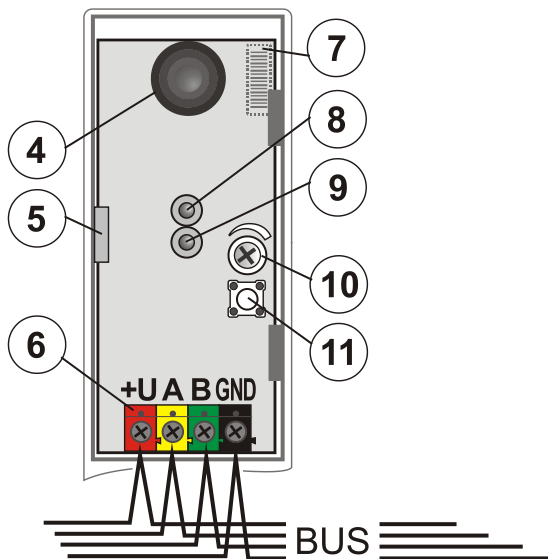

Figure: 4 – GB sensor; 5 – PCB tab; 6 – bus terminals; 7 – bar code (on the inside); 8 – red detector activation indicator; 9 – yellow fault indicator; 10 – sensitivity setting; 11 – tamper contact;

## Detector testing and setting

Using a suitable tool or a hand protected by gloves, one by one, knock all the windows that should be under the detector's protection (A visible deformation of the glass should occur but without any damage). The deformation of glass causes a change in the air pressure of the room which makes the red LED on the detector flash quickly. The detector must react only after a stronger impact on the glass.

**Sensitivity** to air pressure changes can be adjusted with a trimmer (10) on the PCB. Avoid selecting too high a sensitivity - this can result in an increased amount of false alarms.

The complete function of the detector can be tested with a GBT-212 glass-break simulator. After knocking the glass, this simulator will automatically generate the characteristic sound of breaking glass to create the conditions for detector triggering. The red detector LED (8) shall flash for 2 s in such a case.

## Detection characteristics

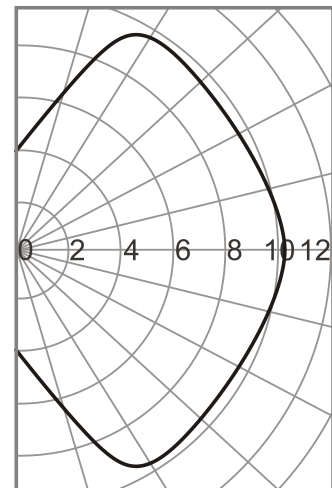

Figure: Detection characteristics of the detector

## Technical specifications

Power	from the control panel bus 12 V (9... 15 V)
Current consumption in standby mode	5 mA
Current consumption for cable choice	5 mA
Recommended installation height	2.5 m above the floor
Detection distance	up to 9 m
Minimum window glass size	0.6 x 0.6 m
Stabilization time after the switching on:	max. 60 s
Dimensions	40 x 100 x 22 mm,
Classification	Grade II
according to	EN 50131-1, EN CLC/TS 50131-2-7-1
Operational environment according to EN 50131-1	II. Indoor general
Operating temperature range	-10 to +40
Also complies with	EN 50130-4, EN 55022



JABLOTRON ALARMS a.s. hereby declares that the JA-110B is in a compliance with the relevant Union harmonisation legislation: Directives No: 2014/30/EU, 2011/65/EU. The original of the conformity assessment can be found at [www.jablotron.com](http://www.jablotron.com) - Section Downloads.



**Note:** Disposing of this product correctly will help save valuable resources and prevent any potential negative effects on human health and the environment, which could otherwise arise from inappropriate waste handling. Please return the product to the dealer or contact your local authority for further details of your nearest designated collection point.

