

The JA-114HN BUS four-input and four-output module

The JA-114HN is a device of the **JABLOTRON** system. It provides 4 wired inputs with configurable balancing, 4 galvanically separated PG outputs and an output for an auxiliary power supply protected by an electronic fuse. It allows you to pre-set the type of balancing for each input and also the value of the balancing resistors. The outputs are designed to be galvanically isolated (2 of them always use the C terminal as a common potential). The module occupies 4 positions in the system and is equipped with a front and a rear tamper contact. The product should be installed by a trained technician with a valid certificate issued by an authorised distributor.

Device description

The module provides 4 inputs, 4 PG outputs and an auxiliary power supply. It is appropriate for the restructure of older wired systems where the detectors remain the same. Thanks to the setting variability of the balancing resistors for every input it is not necessary to intervene in the already-existing installation.

Very often the module is used to control several appliances using the PG outputs. The auxiliary power supply feature can power an additional relay connected to signal output. Inputs can provide feedback about the current appliance status to the system.

Basic features of the inputs, outputs and the auxiliary power supply:

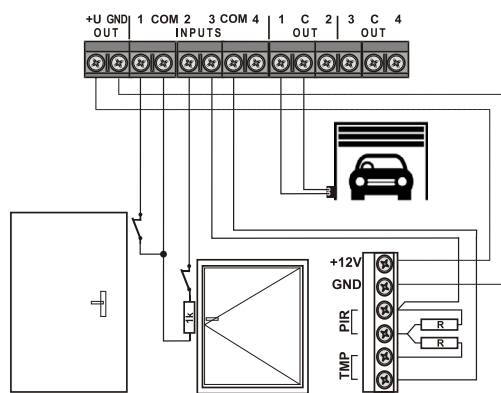

Figure no. 1: Wiring example

INPUTS (INPUTS 1 – 4): The inputs serve as wired connections for wired zones i.e. unbalanced, single balanced, double balanced or *Roller* mode (according to Figure 1). The connection method can be different for every input (every input has an individual setting and also values for balancing resistors). We strongly recommend using balancing resistors with a minimum tolerance of 10%. The COM and GND terminals are connected together.

OUTPUTS (OUT 1 – 4): Galvanically separated PG outputs which switch to the C terminals. The output pair always use the common terminal C. The switching current and voltage should not exceed 500 mA / 38 V.

AUXILIARY POWER (+U and GND): The terminals provide a voltage with a maximum current of 200 mA for powering detectors, auxiliary power relays, contactors or other electric appliances. The output is protected by an electronic fuse and when a short circuit occurs, the module internally disconnects the output and the system shows a module fault. When the short circuit disappears the module restores the voltage.

Installation

The module is designed to be installed in a JA-19xPL installation box (Jablotron), or right in the control panel (JA-10xK).

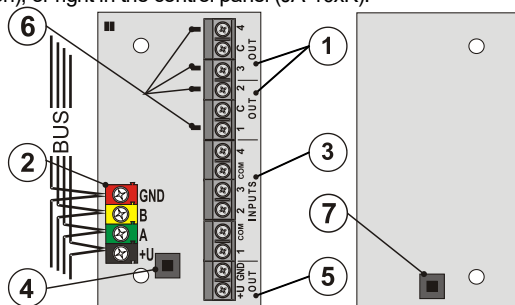

Figure 2: 1 – PG output (1-4) terminals; 2 – BUS terminal, 3 – Input (1-4) terminals; 4 – Front tamper contact; 5 – Output for auxiliary power (+U, GND); 6 – PG output status LED indicators; 7 – Rear tamper contact

- Put the module into the control panel or into an installation box.
 - When installation is performed in a JA-190PL installation box, then the front tamper contact (4) has to be enabled. The rear tamper contact (7) is also recommended to be enabled and equipped with a spring from the supplied accessories. Make a hole inside the JA-190PL box and put the spring of the rear tamper contact through the hole.
 - When the module is installed in the JA-10xK control panel disable the front (4) and rear (7) tamper contacts. The module is protected by the control panel's own tamper contacts.
 - When installation in another Jablotron installation box is required, always pay attention to its installation manual. For the installation to comply with the EN 50131 norm, security grade 2 it is necessary to ensure the minimum functioning of the front tamper contact (4) or ensure protection against tampering with the whole installation box.
- Connect the BUS cable to the BUS terminals (2) and the required inputs (3), outputs (1) and auxiliary power (5).

When connecting the module to the BUS, always switch the power off.



When the module is placed outside the protected premises, it is necessary to protect the BUS cable to the module by a JA-110T BUS isolator.

To set the module to comply with security grade 2 use F-Link SW, Parameters tab and the option "Perform EN50131-1". (See the JA-10xK control panel installation manual)

- Proceed according to the control panel installation manual. Basic procedure:
 - When the system is switched on, the yellow LED starts flashing repeatedly to indicate that the module has not been enrolled to the system yet.
 - Go to the **F-Link** software, select the required position in the **Devices** tab and launch enrollment mode by clicking on the **Enroll** option.
 - Clicking on the **Add new BUS devices** select the JA-114HN module and by a double press confirm enrolling. The yellow LED goes off.
- Set the module parameters such as the functions of inputs and outputs; see the chapter Setting the module properties.
- Close the cover of the installation box or control panel.
- Test input and output functions via the F-Link SW with the Diagnostics tab. Pay attention especially to the line voltage drop when the auxiliary power is used and when PG outputs are used. Switch everything on to simulate a state of maximum current.

Notes:

- The module can be enrolled to the system by entering its production code in the F-Link software. All numbers under the bar code shall be entered (example: 1400-00-0000-0001). The production code is printed on the sticker and glued on module terminals.
- Enrolling can be also performed by pressing the front tamper contact (4).
- The number of modules is limited by the current provided from the control panel BUS terminals and the number of positions available in the control panel.
- When the system is switched on, loading the default statuses can take up to 1 minute.
- Caution!** To enroll the module to the system the next 3 positions have to be free. If the following 3 positions are already occupied, they will be overwritten. When there are not enough positions at the end of the list of devices, only a limited number of inputs will be enrolled to fill in the rest of the positions.
- If less than 4 inputs are to be used, mark the specific input's position in F-link and using the "Delete" key release it for another device.

Setting the module properties

The module properties can be set in the **Devices** tab of the **F-Link** software. When at the module position, use **Internal settings** options to open a dialogue window where you can set the following parameters (* factory settings):

LED indication: Enabled * A short flash by the red LED indicates activation / deactivation on any input.

The JA-114HN BUS four-input and four-output module

Front tamper contact: Disabled *: parameter enables / disables the front tamper contact.

Rear tamper contact: Disabled *: parameter enables / disables the rear tamper contact.

Inputs 1 to 4: tabs with complete settings for the inputs. The settings can be different for every input.

Functions of an input: Enabled*

Disabled – doesn't react (input is disabled).

Enabled – reacts to a change of the contact connected to the input (standby = NC), see figure in the F-Link SW.

Single balanced – An R_{ACT} resistor has to be put in series with an **ACT** activation contact (see figure in F-Link). To set its value use the **Balancing resistor** parameter, it is immediately visible when you select this function. The input is activated when the resistance of the loop changes by 30%.

Double balanced – An R_{TMP} resistor has to be put in series with a **TMP** tamper contact and the activation contact has to be bridged connected in parallel by an R_{ACT} resistor (see Figure 3 and in F-Link SW). To set its value, use the **Balancing resistor** parameter. The values of the R_{TMP} and R_{ACT} balancing resistors can be different, see the **Balancing resistor** parameters.

The loop can have up to 3 states: **Standby** – the value of measured loop resistance equals R_{TMP} . **Activation** – the value of measured loop resistance equals $R_{TMP} + R_{ACT}$ (if multiples are needed it is $R_{TMP} + n * R_{ACT}$). **Tamper** – the value of measured loop resistance is different than previous values. To ensure reliable detection the device assumes a resistivity tolerance ($\pm 30\%$).

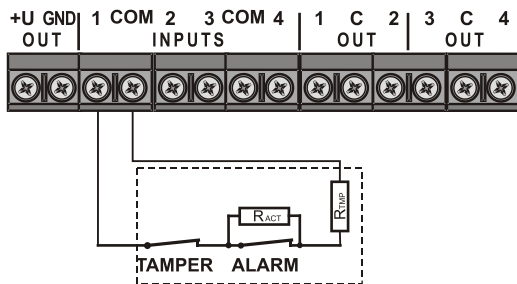

Figure no. 3: Double balanced loop

Double balanced Oasis – settings of the input module are fully compatible with parameters of the input modules and control panels of Oasis systems. This mode allows you to connect up to 5 detectors in one loop (see Figure no. 4 and in F-Link SW).

The loop can have up to 3 states: **Standby** – the value of measured loop resistance is from 700Ω to $1.3 \text{ k}\Omega$, **Activation** – the value of measured loop resistance is from $1.4 \text{ k}\Omega$ - $7.8 \text{ k}\Omega$, **Tamper** – the measured loop resistance is lower than 600Ω or higher than $7.9 \text{ k}\Omega$.

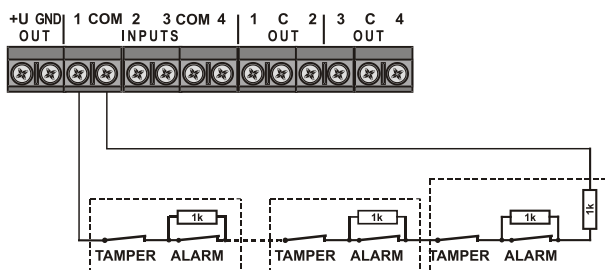

Figure 4: Double balanced loop - OASIS

Rollerblind (roller) – reacts to short repeated pulses with a sensitivity adjustable to two levels: **Impulse 1** = activation by 3 pulses within 2 minutes max.; **Impulse 2** = activation by 5 pulses within 2 minutes max.

Input inverted reaction: can be used for an **Enabled** or **Single balanced** input. The default (disabled) reaction is set to disconnection from COM (NC)*. By enabling this option you can set the opposite reaction to grounding (NO).

Impulse: can be used for all functions except **Roller**. The default option is disabled*, the input works in status mode. It means that the input reacts to disconnection / connection (activation and deactivation) of the loop from / to ground. Enabling this input option will only react to activation (connection or disconnection of GND according to the **Inverted input reaction** option). After 2 s it goes to standby automatically.

Balancing resistor / EOL: it is meant for a **Single balanced loop** and for a **Double balanced loop**. The default value is $1 \text{ k}\Omega$.

For a **Single balanced loop** select the R_{ACT} value of balancing resistor from the pre-set options. The last option is **Optional**, it accesses the **Value Ract** parameter. Here simply fill in the required value in $\text{k}\Omega$ (max. $10 \text{ k}\Omega$). As a separator use a decimal point or the "k" symbol. F-Link checks the entered value and if it's out of range or invalid, the option is red.

For a **Double balanced loop** select the R_{TMP} and R_{ACT} value of resistor for the detection of tampering and activation from the pre-set values (the selected value is valid for both resistors). The last option is **Optional**, it accesses the **Value Ract**, **Value Rtmp** and **Multiplicity** parameters (max. 5). These parameters allow you to select specific values of resistors and to choose how many detectors are going to be used in one loop. Select the resistors values from the offered list or simply fill in the required value in $\text{k}\Omega$ (max. $10 \text{ k}\Omega$). As a separator use a decimal point or the "k" symbol. F-Link checks the entered value and if it's out of range or invalid, the option is red.

Delayed input reaction: a time filter for increasing immunity and to suppress false activations, 0.5 s^* (options $0.1 \text{ s} \dots 300 \text{ s}$). It tells you how long the input has to be activated to trigger an alarm in the control panel. For the functions **Double balanced** and **Double balanced Oasis** the option range is from 0.5 s to 300 s .

Copy of input settings: thanks to this button you can copy the settings of a currently programmed input to another input of the same module.

Outputs: Disabled*: A tab where a specific PG of the control panel can be assigned to specific outputs 1 – 4 (1). When several PG outputs are assigned to one output then it is driven by OR logic (when one PG output is ON then the output is also ON). The **Test** button checks the PG output function. When the PG output is switched ON it is indicated by a red LED (6) at the specific output and by a red light in the F-Link SW indication field (next to the **Test** button). When the internal settings window is closed all outputs are switched off.

Input measuring / diagnostics: here at this tab you can see the currently measured resistance at a specific input (loop). Graphic representation fully respects the input settings (function, balancing and its value). It visualizes the current status of the measured value. Thanks to the recording of measured values over time it shows a visible curve with all changes and you can test all detectors this way.

Technical specifications

Power	from control panel BUS 12 V DC (9 – 15 V)
Current consumption:	
- Nominal consumption - to calculate backup	11 mA
	all inputs connected to GND
	(+ consumption of connected devices)
- Maximal consumption - for cable selection	26 mA
	(+ consumption of connected devices)
Voltage from +U	12 V DC (9 – 15 V)
Maximum acceptable load from +U (electronic fuse)	< 200 mA
Maximum acceptable current / voltage switched by each output	500 mA/38 V
Max. measured resistance at input	20 $\text{k}\Omega$
Max. cable length connected to inputs	100 m
Dimensions	77 x 40 x 31 mm
Weight	26 g
Classification	security grade 2/environmental class II
- according to	EN 50131-1, EN 50131-3 (ACE type B)
- environment	Indoor general
- operational temperature range	$-10 \text{ }^\circ\text{C}$ to $+40 \text{ }^\circ\text{C}$
- average humidity	75 %, non-condensing
- certification body	Trezor Test s.r.o. (no. 3025)
Also complies with	EN 50130-4, EN 55022



JABLOTRON ALARMS a.s. hereby declares that the JA-114HN is in a compliance with the relevant Union harmonisation legislation: Directives No: 2014/30/EU, 2011/65/EU. The original of the conformity assessment can be found at www.jablotron.com - Section Downloads.

Note: Disposing of this product correctly will help save valuable resources and prevent any potential negative effects on human health and the environment, which could otherwise arise from inappropriate waste handling. Please return the product to the dealer or contact your local authority for further details of your nearest designated collection point.