

The JA-151ST Wireless combined smoke and heat detector

The JA-151ST is a component of the JABLOTRON alarm system. It is used to detect fire hazards in the interior of residential or commercial buildings. The detector can be installed in mobile homes or caravans. The product is not designed to be installed in industrial premises. The JA-151ST detector uses wireless communication and it is powered with three AA batteries. The detector should be installed by a trained technician with a valid with a valid manufacturer's certificate.

The detector indicates a fire hazard using the built-in LED indicator and acoustic signalling.

The JA-151ST consists of two independent detectors – an optical smoke detector and a heat detector. The optical smoke detector works on the principle detection of scattered light. It is very sensitive to large dust particles which are present in dense smoke. It is less sensitive to smaller particles generated by the combustion of liquids such as alcohol. That is why the fire detector also contains a built-in heat detector which has a slower reaction but is much better at detecting fire which generates only a small amount of smoke.

Detector range and location

The smoke detector must be installed so that any smoke easily drifts into the detector owing to natural thermal currents, e.g. on the ceiling. It is suitable for residential buildings but not suitable for free spaces, outdoor environments or interiors with extremely high ceilings (above 5 m) where fire by-products can disperse over a large area – the smoke would not reach the detector position.

Do not install the detector in an environment exposed to dust, cigarette smoke and steam. Dusty environments shorten the detector's lifespan.

The detectors should be installed by a trained technician with a valid manufacturer's certificate.

Detectors should be installed in the building according to the project documentation. If such documentation is not available, their position should comply with the effective standards for fire alarm signalling systems.

The detector must always be placed in the section leading to the exit of the building (escape route), see Fig. 1. If the building has a floor area greater than 150 m², installation of an additional detector in some other suitable place is required, see Fig.2.

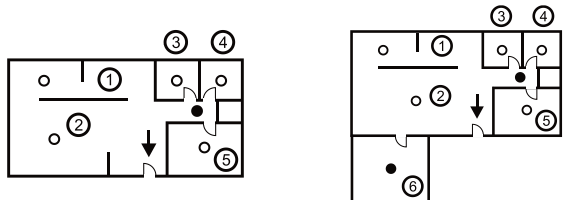

Fig 1

Fig 2

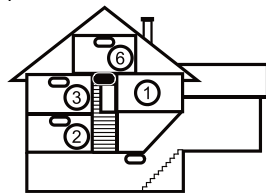

Fig 3

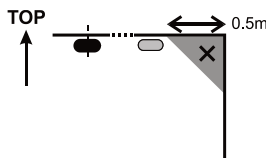

Fig 4

● centre of the room, best location ○ acceptable location

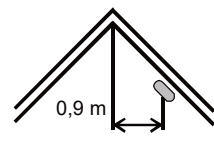

Fig 5

In multi-storey flats and family houses the detector should be installed above the stairs. It is recommended to place additional detectors in rooms where people sleep. See Fig 3.

Installation on level ceilings

Place the detector in the centre of the room if possible. The detector must not be recessed into the ceiling due to the possible existence of a cool air layer on the ceiling. Never place the detector in the corner of the room (always keep at least 0.5 m distance from the corner - see Fig 4). There is an insufficient circulation of air in the corners.

Installation on sloping ceilings

If the ceiling is not suitable for mounting on a level surface (e.g. a room under a roof ridge), the detector can be installed as in Fig. 5.

Walls, partitions, barriers and lattice ceilings

The JA-151ST detector must not be installed closer than 0.5 m from any wall or partition. A narrow room with a width of less than 1.2 m requires the detector(s) to be placed at a distance of at least one third of the room's width away. In a case when a room is separated into sections with furniture, racks or semi partition walls which do not reach the ceiling, the space is considered to be fully separated if the gap between the top of these and the ceiling does not exceed 0.3 m. A free space of at least 0.5 m is required under and around the detector. Any irregularities of the ceiling (e.g. girders) exceeding 5 % of the ceiling height should be considered a wall and the above mentioned limitations should apply.

Ventilation and air circulation

The detectors must not be installed directly by ventilation or air conditioning vents. In the case of air being supplied through a perforated ceiling, each detector must be placed so that no perforation hole occurs within 0.6 m of the detector.

Avoid installing the detector in the following locations:

- places with poor air circulation (niches, corners, apexes of A-shaped roofs, etc.)
- places exposed to dust, cigarette smoke or steam
- places with over-intense air circulation (close to ventilators, heat sources, air conditioning outlets, etc.)
- in kitchens and other cooking places (because steam, smoke or oily fumes can cause false alarms or reduce detector sensitivity).
- beside fluorescent lights or energy-saving light bulbs (electrical interference can cause a false alarm)
- in areas with lots of small insects

Warning: Most false alarms are caused by improper detector location.
See CEN/TS 54-14 standard for detailed installation guidelines.

Installation

When installing the detector, abide by the procedures recommended in the previous paragraphs.

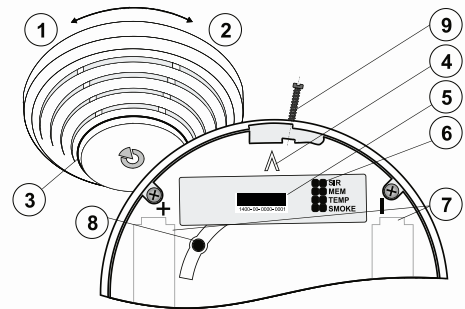

Fig 6: 1 – detector cover opening; 2 – detector cover closing; 3 – optical status signalling; 4 – arrow showing where to insert the detector; 5 – production code; 6 – configuration terminals; 7 – battery holders; 8 – button for test; 9 – arresting screw

1. Open the detector cover, by turning it anti-clockwise (1)
2. Attach the plastic base to the selected place using screws
3. Use the terminals (6) to set the required detector function – see the table below

1	ON	Siren disabled	3	OFF	Smoke (EN 14604 or EN 54-7) or heat (EN 54-5)	
	OFF	Siren enabled (EN 14604)	4	OFF		
2	ON	Memory disabled	3	OFF	Smoke only (EN 14604 or EN 54-7) (not heat)	
	OFF	Memory enabled (EN 54-7 and EN 54-5)	4	ON		
			● ON	3	ON	Heat only (EN 54-5) (not smoke)
			● OFF	3	ON	
			● ON	4	OFF	Both smoke and heat (both conditions at the same time)
			● OFF	4	ON	

When the detector is installed in caravan trailers, use only the "smoke only" or "both smoke and heat" settings.

The JA-151ST Wireless combined smoke and heat detector

4. Proceed according to the control panel installation manual.

Basic procedure:

- There must be the JA-11xR radio module enrolled in the system.
 - Go to the **F-Link** program, select the required position in the **Devices** window and launch enrollment mode by clicking on the Enroll option.
 - When you insert all batteries into the detector, an enrollment code is sent to the system – its sending is confirmed with a short flash of the LED indicator (3).
Note: The detector can also be enrolled into the system by entering its serial number (5) in the F-Link program or using a bar code scanner). All numbers stated under the bar code shall be entered (1400-00-0000-0001).
5. **Insert the detector into the plastic base.** The detector can be inserted into the plastic base in one position only. It is marked with **arrows** (4) on both plastic parts. Close the detector cover by turning it clockwise (2).
6. In order to be fully compliant with regulations, it is necessary to lock the cover in place with the use of an (9) arresting screw.

Note: Detector cover closing is blocked unless all 3 batteries are inserted!

The mounting base must not be replaced by bases meant for detectors without the test button consisting of pressing the body of the detector.

Detector setting

The detector properties can be set in the **Devices** window in the **F-Link** program or with configuration terminals.

The **Reaction** option in the **Devices** window allows you to set the type of reaction of the system to the activation of the enrolled detector. The configuration terminals on the detector PCB determine other reactions:

SIR enables deactivating the built-in siren.

MEM alarm memory signalling – if enabled, the detector LED remains active for an additional 24 hours. Signalling can also be terminated by pressing the detector body against the base.

SMOKE and TEMP combination of these terminals defines whether the detector will react to smoke and heat.

Fire alarm

A fire alarm is signalled acoustically and optically according to the settings.

When the conditions for fire alarm triggering are met (smoke is detected in the room, the alarm temperature is reached, or both conditions are met), the detector signals the danger by sounding the siren and quick flashing of the LED indicator (3). The alarm information is concurrently sent to the system control panel.

Silencing the siren during an alarm: The siren can be silenced by pressing the detector body against the base. The siren is inactive for 10 minutes. If the detector still detects smoke or heat then, the siren is activated again.

When the need arises (e.g. in the case of detector failure), it is possible to postpone siren reactivation by up to 12 hours. This can be done by pressing the detector again for 5 s after silencing the siren. When the detector chirps, you have to release the pressure within 1 s. The switchover to postponed siren mode is confirmed with 5 chirps. The detector LED flashes all the time during the postponement.

Alarm memory: If it is enabled, LED indication continues even when the smoke clears or when the temperature decreases. The slow-flashing indication lasts 24 hours unless it is terminated by pressing the detector body.

Tamper alarm: When the detector cover is opened, the detector sends a tamper signal to the control panel.

Detector testing and maintenance

The detector should be tested at least once per month. To test the detector press the detector against the base and wait until an LED indicator switches on. The LED flashing signals switchover to the test mode. The LED is flashes for the whole duration of the test. When the test is complete, the LED switches off. The detector then signals the result. If the detector beeps once, the test has been done successfully. If a failure is discovered, the LED flashes and beeps three times. If the battery is low, there is no acoustic signalling but just one flash when the test is completed.

The complete functioning of the optical part of the detector can be tested with a test spray (e.g. SD-TESTER). The heat sensor can be tested with heated air (e.g. with a hair dryer).

If the control panel is not in SERVICE mode, a fire alarm is triggered.

Warning: never test the detector with fire.

Fault indication

The detector checks its functioning. If it discovers a fault, it chirps and flashes the LED three times and then flashes briefly three times every 30 s.

A detector test can be carried out when a fault is signalled. To test the detector, press its whole body against the base. During the test the detector checks whether there is still a fault. The red LED flashes during the test. When the test is completed, the LED stops flashing and the detector then signals the result. A persistent fault is signalled by 3 flashes and 3 beeps. If the fault has been fixed, the detector chirps briefly.

If you have not managed to fix the fault, the detector must be sent to a service centre.

Battery replacement

The detector checks the battery status and if the batteries are running low, the detector signals that they need replacing by short flashes repeated every 30 s. The information is also sent to the control panel. Replace the batteries as soon as possible.

Exchange procedure:

- If the detector is already enrolled to the system it's necessary to enter service mode
- open the detector
- remove the old batteries
- press and hold the test button (8) until the LED (3) goes ON
- when the LED goes OFF, it shows the capacitors inside the detector have been discharged
- insert some new batteries

Always replace all three batteries with the same type and manufacturer.

Use only high-quality 1.5 V AA alkaline batteries.

Do not throw used batteries into ordinary household waste. Deposit them at authorized collection points.

Removal of the detector from the system

The system reports any possible detector loss. If you have removed it on purpose, you also have to erase it from the corresponding address in the control panel memory.

Technical specifications

Power	3 x Alkaline battery type LR6 (AA) 1.5 V/2.4 Ah
	Please note: Batteries are not included
Quiescent current consumption	22 µA
Maximal current consumption	50 mA
Low battery voltage	3.3 V
Typical lifetime	approx. 3 years
Smoke detection	optical light scattering
Smoke detector sensitivity	$m = 0.11 \div 0.13$ dB/m
	pursuant to EN 14604, EN 54-7
Heat detection	class A1 according to EN 54-5
Alarm temperature	+ 60 °C to +65 °C
Communication band	868.1 MHz, Jablotron protocol
Effective Radiated Power (ERP)	10 mW
Communication range	approx. 300 m (unrestricted area)
Dimensions	diameter 126 mm, height 50 mm
Weight	150 g
Operating temperature range	-10 °C to +70 °C
Also complies with	EN 14604, EN 54-5, EN 54-7, ETSI EN 300 220-1,-2, EN 50130-4, EN 55032, EN 62368-1, EN IEC 63000
Can be operated according to	ERC REC 70-03
Recommended screw	4 x  ø 3.5 x 40 mm (countersunk head)



1438-CPR-1006

JABLOTRON ALARMS a.s. hereby declares that the JA-151ST is in a compliance with the relevant European Union harmonisation legislation and regulation (EU) no. 305/2011 of the European parliament and of the Council and directives no. 2014/53/EU, 2014/35/EU, 2014/30/EU, 2011/65/EU. The original of the conformity assessment can be found at www.jablotron.com - Section Downloads.



Note: Disposing of this product correctly will help save valuable resources and prevent any potential negative effects on human health and the environment, which could otherwise arise from inappropriate waste handling. Please return the product to the dealer or contact your local authority for further details of your nearest designated collection point.